



兴源实业

XINGYUAN GROUP

XINGYUAN INDUSTRY GROUP

兴源实业

Head Office Address: Xingyuan Group Building, Nanlv Industry Zone, Xinji City, Hebei China

集团总公司办公地址：河北省辛集市南吕村工业区，兴源实业大楼

Tel/电话:+86-311-83333333/13473768866 Fax/传真: +86-311-83335052

www.xygrup.cn

Xingyuan Profile

Xingyuan Industry Group as a family industry factories united group, established in 1990, based on agriculture field, Committed to biomass comprehensive utilization, energy saving and environment protection field business. with multi business such us agriculture products, charcoal & activated carbon, equipment for charcoal & activated carbon, boiler equipment, biotech power plant system, foam plastic production and machinery and the chemical trading business, totally 3 Industrial field and 7 sectors business. Till to now already including 11 companies through sole proprietorship and shareholding. Members and layout as bellow:

Agriculture

-- Xingyuan Agriculture

Charcoal & Activated Carbon

-- Xingyuan Activated Carbon

-- Xingyuan Biotech

-- PT.Xingyuan Indonesia Carbon Active

-- Anguo Shenjie Ecotech

Reactivation Centres

-- Yantai Dinglong Reactivation

Machinery

-- Xingyuan Machinery

-- Shuangliang Boiler Equipment

Foam & Plastic

-- Xingyuan Foam Plastic

-- Yuanxiang Chemical

Trading

-- Dingang Impex

With the shortage of resources and the deterioration of environment in China, Xingyuan Industry is gradually shifting our focus and try to realize the program of combining comprehensive utilization of biology with environmental protection based on the practical experience and strong technical research team, find the final solution for biomass comprehensive utilization and sustainable development industry chain. We are working on it for tomorrow of the Earth.

Enterprise Concept - Clean energy , environment protection ,energy saving

This is the 20st more year after Xingyuan foundation, May you have a better life with the companionship Of Xingyuan!

In this society full of Competition , nothing could move people easily, except by sincerity and responsibility. In this environment where only the fittest survives, nothing can remain youthful forever, except by reform and innovation. Xingyuan, with a development history of more then 20 years, is still young in comparison with the centuries-old stores having ever-green foundations.

Clean energy , environment protection ,energy saving .Green world , create a better future ,Xingyuan will do a better job.

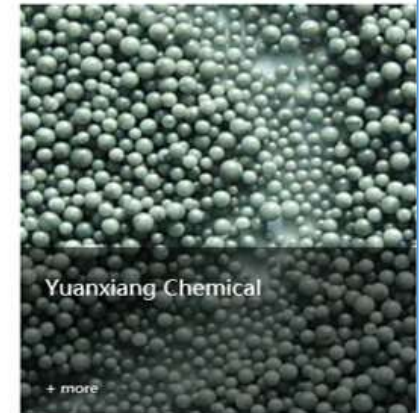

兴源实业概况

Xingyuan as a industry factory group ,group members including following self-own factory and overseas branch and corporate company.

Xingyuan Agriculture

Xingyuan Activated Carbon

Xingyuan Foam Plastic

Xingyuan Machinery

Yuanxiang Chemical

Shuangliang Boiler Equipment

Xingyuan Biotech

PT.Xingyuan Indonesia Carbon Active

Anguo Shenjie Ecotech

Yantai Dinglong Reactivation

Dingang Impex

Benefiting the nation and the people is the living rules for Xingyuan.

Xingyaun Industry Group

兴源活性炭
Xingyuan Activated
Carbon

兴源农业合作社
Xingyuan Agriculture

兴源生物科技
Xingyuan Biotech

兴源机械
Xingyuan Machinery

兴源印度尼西亚
PT.Xingyuan Indonesia
Carbon Active

兴源泡塑
Xingyuan Foam Plastic

双良锅炉
Shuangliang Boiler
Equipment

远翔化工
Yuanxiang Chemical

鼎昂进出口
Dingang Impex

安国神洁环保科技
Anguo Shenjie Ecotech

鼎龙生物科技（山东）
Yantai Dinglong
Reactivation

XINGYUAN INDUSTRY ORGANIZATION CHART

Chairman Hao

G.M for Business

Finance Department

G.M for Production

Business Department

QC Department

Production Department

Purchase Department

Machining Department

International Market

Domestic Market

Dingang Impex

Yuanxiang Chemical

Xingyuan Activated Carbon

Anguo Shenjie Ecotech

Xingyuan Biotech

Yantai Dinglong Reactivation

Xingyuan Foam Plastic

Xingyuan Agriculture

PT.Xingyuan Indonesia Carbon Active

Shuangliang Boiler Equipment

Xingyuan Machinery



生产场地 Factory



生产场地 Factory

兴源实业大楼 Head Office



场地Factory show



Activated Carbon Technology

More than 25years ,Focus on AC Tech
Drop by Drop ,Year by Year
Never stop, Keep Forward

Activated carbon production process technical drawing instruction

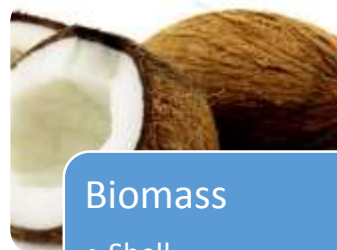

Biomass

- Shell
- Wood
- coal

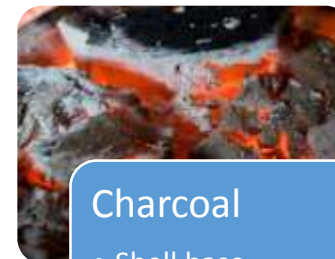

Charcoal

- Shell base
- Wood base
- Coal base

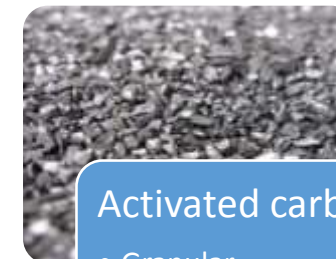

Activated carbon

- Granular
- Powder
- pellets

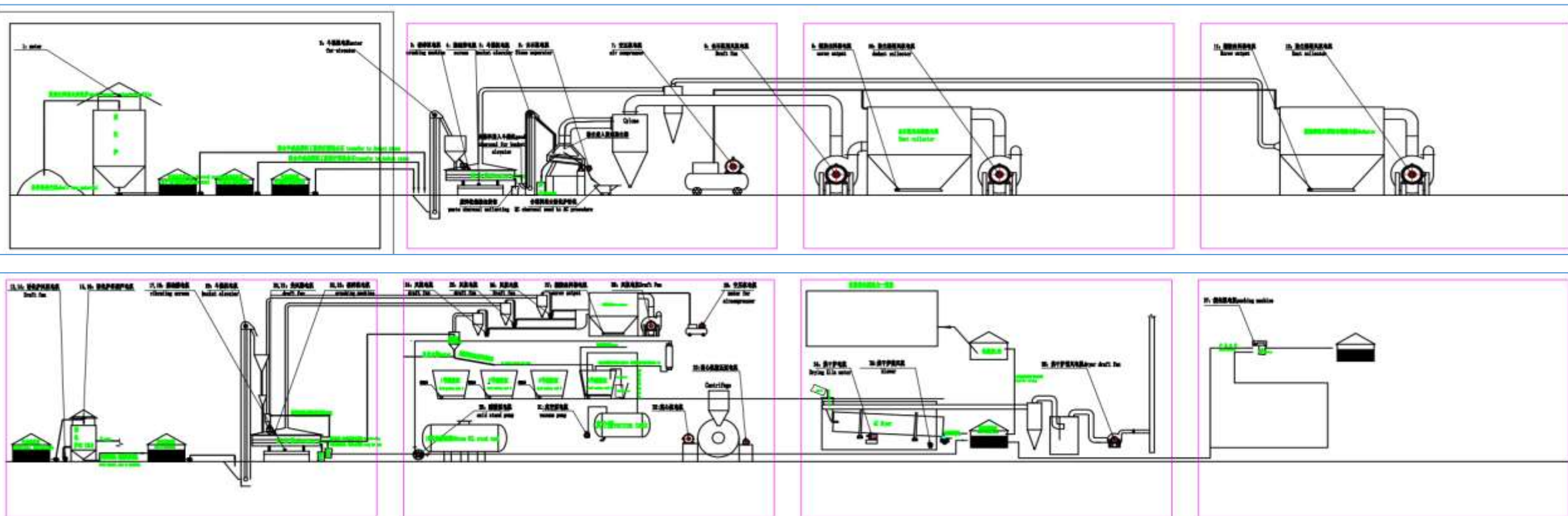

Xingyuan Activated Carbon

From 1990 , Charcoal as Xingyuan Group first business ,already more than 20years history ,from 1997,Xingyuan begin to produce activated carbon as development for charcoal ,now Xingyuan have carbonizing furnace 4set , Activation Rotary Kiln 6 set , and Upright Kiln 3 set , factory take land more then 70000square meter ,yearly capacity for activated carbon more then 6000tons , become the first top three in North China carbon active enterprise .

Beginning from 2008, Xingyuan begin import coconut shell charcoal raw material from Indonesia ,Philippine ,Vietnam etc. south east countries ,import wood charcoal from South Afirca countries, keep the good relationship with suppliers till to now .

Based on the years technology and manufacturing experience , Xingyuan activated carbon export to Japan ,S.Korea and other countries , get more focus by clients and good reputation.



Vertical furnace





Upright Kiln



Rotary Kiln



Rake Furnace



Regeneration furnace

Xingyuan Activated Carbon

兴源活性炭旗下分为两个品牌，家用工业活性炭墨宝和家用活性炭洁万家。

Xingyuan Activated carbon have two brand , for home use CLEANHOMES ,and for Industrial use MOBAO



Industry Use MOBAO



Home Use CLEANHOMES

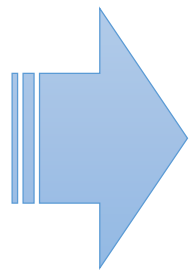

Shell based



Wood based

Charcoal Furnace

Xingyuan AC Kiln and Charcoal Machine Patent



实用新型专利证书

Certificate of Utility Model Patent

中华人民共和国国家知识产权局

STATE INTELLECTUAL PROPERTY OFFICE OF THE PEOPLE'S REPUBLIC OF CHINA



Biomass Technology

Start from biomass ,final products including Charcoal--- Syngas---Electricity--- Activated Carbon—Liquid ,based on but different traditional biomass power plant

G+C+E+AC+L Biomass Cogeneration Project Introduction

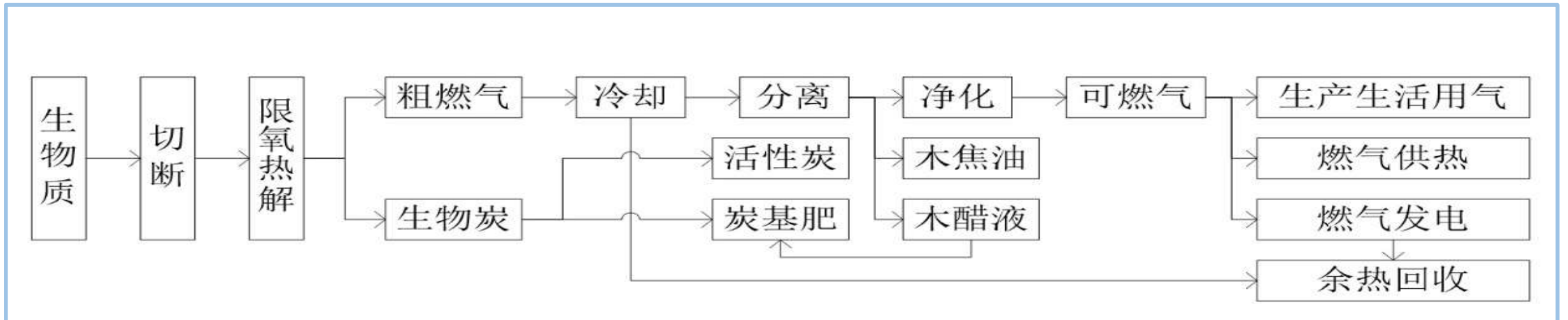
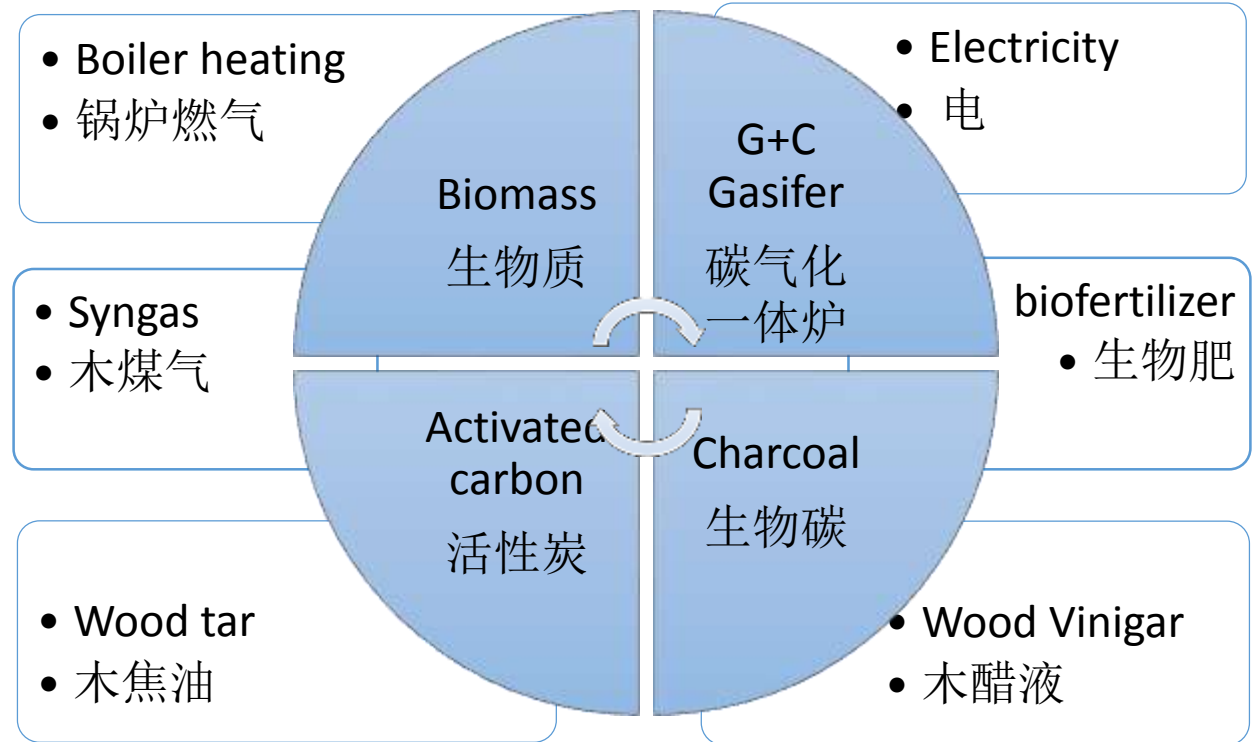

Xingyuan Biotech

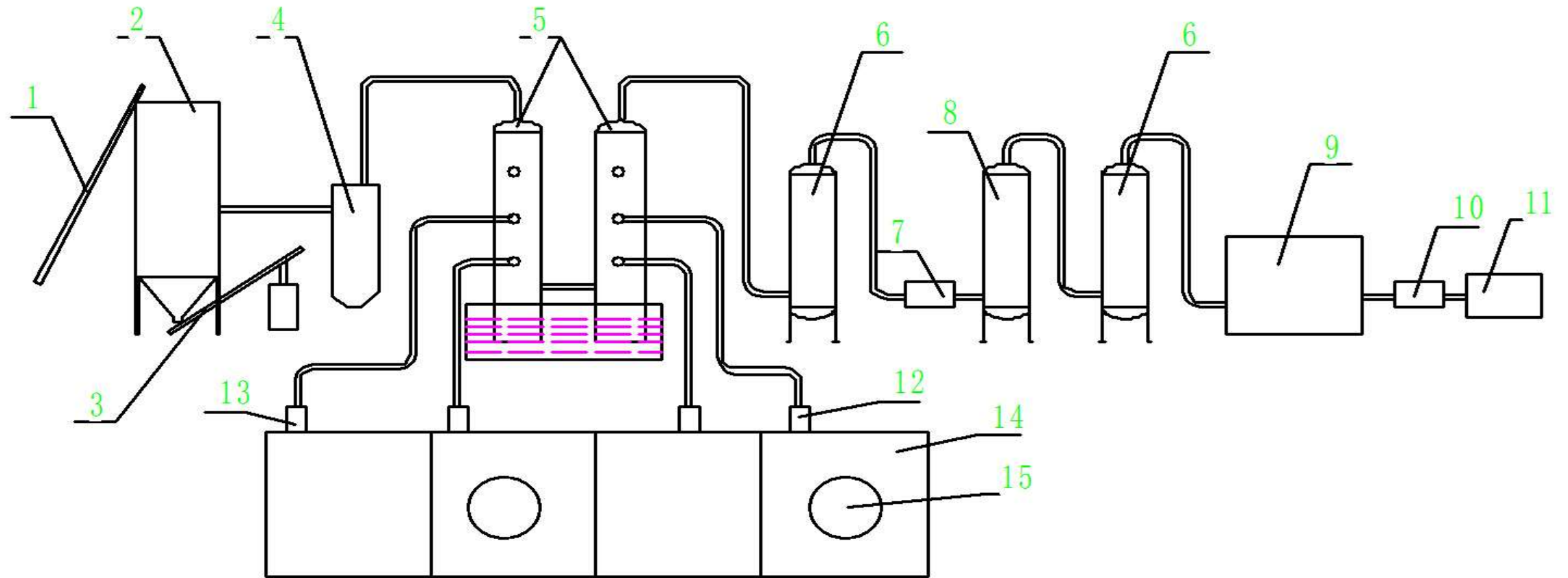

- 1、上料机 feeding machine, 2、气化炉 gasifier, 3、出料机 output device,
4、除尘器 dust collectors, 5、喷淋塔 spray shower tower, 6、过滤器 filters,
7、引风机 draft fan, 8、风冷 wind cooling device, 9、气柜 gas stock tank,
10、引风机 draft fan, 11、发电机 generator, 12、冷水泵 cooling water pump
13、循环泵 water recycling pump, 14、水池 water pool, 15、冷却塔 cooling tower

Xingyuan Biotech G+C Gasifier



Xingyuan Biotech G+C Gasifier & Filter





100037

北京市西城区阜成门外大街 22 号外经贸大厦第 11 层 1101-16.
北京联瑞联丰知识产权代理事务所(普通合伙) 朱广存

发文日:

2015 年 05 月 14 日



申请号或专利号: 201520307391.1

发文序号: 2015051400524530

专利申请受理通知书

根据专利法第 28 条及其实施细则第 38 条、第 39 条的规定, 申请人提出的专利申请已由国家知识产权局受理。现将确定的申请号、申请日、申请人和发明创造名称通知如下:

申请号: 201520307391.1
申请日: 2015 年 05 月 13 日
申请人: 辛集兴源生物科技有限公司
发明创造名称: 一种节能型连续炭化炉

经核实, 国家知识产权局确认收到文件如下:

- 实用新型专利请求书 每份页数:4 页 文件份数:1 份
- 权利要求书 每份页数:1 页 文件份数:1 份 权利要求项数: 3 项
- 说明书 每份页数:4 页 文件份数:1 份
- 说明书附图 每份页数:1 页 文件份数:1 份
- 说明书摘要 每份页数:1 页 文件份数:1 份
- 摘要附图 每份页数:1 页 文件份数:1 份
- 专利代理委托书 每份页数:2 页 文件份数:1 份
- 费用减缓请求书 每份页数:1 页 文件份数:1 份
- 费用减缓证明 每份页数:1 页 文件份数:1 份

提示:

1. 申请人收到专利申请受理通知书之后, 认为其记载的内容与申请人所提交的相应内容不一致时, 可以向国家知识产权局请求更正。
2. 申请人收到专利申请受理通知书之后, 再向国家知识产权局办理各种手续时, 均应当准确、清晰地写明申请号。

审查员: 魏红恩(电子申请)

审查部门: 专利局初审及流程管理部



200101 纸件申请, 回函请寄: 100088 北京市海淀区蓟门桥西土城路 6 号 国家知识产权局受理处
2010. 2 电子申请, 应当通过电子专利申请系统以电子文件形式提交相关文件。除另有规定外, 以纸件等其他形式提交的文件视为未提交。

Patent for G+L+E+C Gasifier



100037

北京市西城区阜成门外大街 22 号外经贸大厦第 11 层 1101-16.
北京联瑞联丰知识产权代理事务所(普通合伙) 朱广存

发文日:

2015 年 05 月 14 日



申请号或专利号: 201510243030.X

发文序号: 2015051400677350

专利申请受理通知书

根据专利法第 28 条及其实施细则第 38 条、第 39 条的规定, 申请人提出的专利申请已由国家知识产权局受理。现将确定的申请号、申请日、申请人和发明创造名称通知如下:

申请号: 201510243030.X
申请日: 2015 年 05 月 13 日
申请人: 辛集兴源生物科技有限公司
发明创造名称: 一种生物质炭、气、油、液、热、电多联产的装置及其方法

经核实, 国家知识产权局确认收到文件如下:

- 发明专利请求书 每份页数:5 页 文件份数:1 份
- 权利要求书 每份页数:2 页 文件份数:1 份 权利要求项数: 6 项
- 说明书 每份页数:6 页 文件份数:1 份
- 说明书附图 每份页数:2 页 文件份数:1 份
- 说明书摘要 每份页数:1 页 文件份数:1 份
- 摘要附图 每份页数:1 页 文件份数:1 份
- 专利代理委托书 每份页数:2 页 文件份数:1 份
- 费用减缓请求书 每份页数:1 页 文件份数:1 份
- 费用减缓证明 每份页数:1 页 文件份数:1 份
- 实质审查请求书 每份页数:1 页 文件份数:1 份

提示:

1. 申请人收到专利申请受理通知书之后, 认为其记载的内容与申请人所提交的相应内容不一致时, 可以向国家知识产权局请求更正。
2. 申请人收到专利申请受理通知书之后, 再向国家知识产权局办理各种手续时, 均应当准确、清晰地写明申请号。

审查员: 宗欣(电子申请)

审查部门: 专利局初审及流程管理部



200101 纸件申请, 回函请寄: 100088 北京市海淀区蓟门桥西土城路 6 号 国家知识产权局受理处
2010. 2 电子申请, 应当通过电子专利申请系统以电子文件形式提交相关文件。除另有规定外, 以纸件等其他形式提交的文件视为未提交。

Xingyuan Biotech Wood Vinegar Distillation

PALM SHELL CARBONIZING AND WOOD VINEGAR DISTILLATION PROCEDURE

棕榈壳碳化炉和木醋液提取精炼工艺流程图

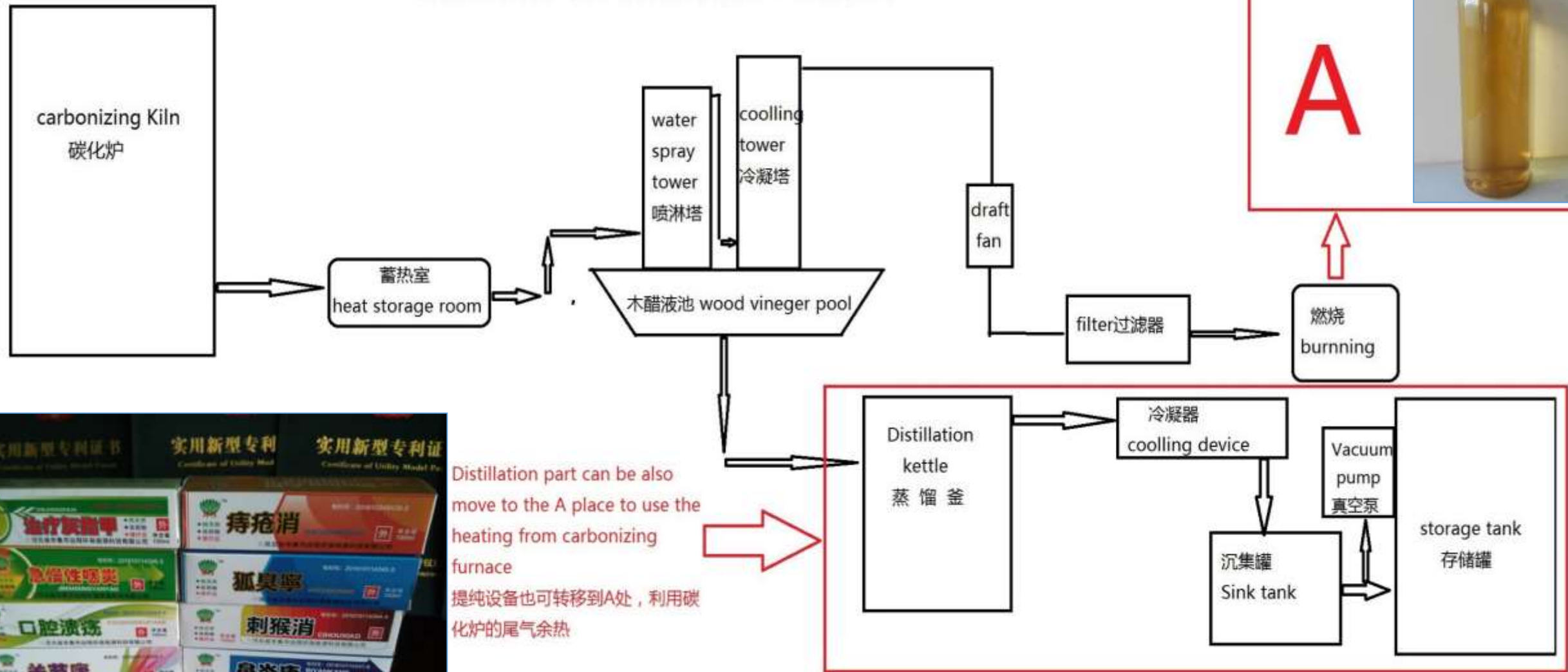

Distillation part can be also move to the A place to use the heating from carbonizing furnace

提纯设备也可转移到A处，利用碳化炉的尾气余热



Xingyuan Wood Vinegar&Bio Tar Patent



实用新型专利证书

Certificate of Utility Model Patent

中华人民共和国国家知识产权局

STATE INTELLECTUAL PROPERTY OFFICE OF THE PEOPLE'S REPUBLIC OF CHINA



Bio-fertilizer Production line



**Microbial
culture
chamber**

Xingyuan Bio-fertilizer Products

共和百康
GHOBER

中华人民共和国农业部
登记证号：绿生肥(2004)准字(144)号
执行标准：GB20287-2008
发明专利号：ZL02103756.6

有机物料腐熟剂

共和百康
GHOBER

中华人民共和国农业部
登记证号：绿生肥(2004)准字(144)号
执行标准：GB20287-2008
发明专利号：ZL02103756.6

有机物料腐熟剂

纳米碳

净含量：20kg

共和百康(北京)生物工程研究院有限公司 联合出品
辛集兴源生物科技有限公司

销售电话：010-59195013



共和百康
GHOBER

发明专利号：ZL02103756.6

有机物料腐熟剂

产品介绍

共和百康 有机物料腐熟剂，是国内率先引进的成熟的微生物菌与生物炭的复合技术及先进的生产工艺。由日本共和商事株式会社与日本松本微生物研究所、中国科学院微生物所和中国农科院等方面专家技术指导开发研制的国家专利产品。是科学院复合而成的一种高效、绿色环保的有机物料腐熟剂。

本品具有如下特点：

- 一、适用范围广，本品用于人、畜、禽、粪便和各种作物秸秆、花生壳、稻糠、锯木、树叶、蘑菇下脚料、酒糟、甘蔗渣、药渣、糖糟渣、城市生活垃圾、污水处理厂污泥等有机固体废物的高效处理。
- 二、起温迅速快，升温高，能快速提高物料温度，有助于快速将环境菌分解转化，有效杀灭有机物中的细菌种好虫卵及各种病原菌。
- 三、能快速消除臭味，降解彻底，肥力能力强，不返臭。
- 四、操作方便，有机物料2-3方投入1kg本品即可，能够快速的将各种有机物料处理成腐熟有机肥。

注意事项：

- 1、本品为复合微生物产品，不可与杀菌剂混用。
- 2、本品应存放于阴凉、干燥通风的仓库，防止曝晒。
- 3、因各用户的原材料有别，使用方法有不同，具体使用方法请与公司技术部门直接联系。
- 4、本产品保质期10个月，生产日期见袋内合格证。

永济共和百事康生物技术有限公司 联合生产
辛集兴源生物科技有限公司

地址：河北省辛集市张古庄镇商品村工业区 电话：0311-83335688



有机物料腐熟剂

中华人民共和国农业部
登记证号：绿生肥(2004)准字(144)号
执行标准：GB 20287-2008

日本共和商事株式会社
日本松本微生物研究所技术支持

净重 20kg

北京益微康壮生物投资有限公司 出品
北京松源兴业生物技术有限公司

河北省辛集市张古庄镇商品村工业区4022号

共和百康
GHOBER

有机物料腐熟剂

BBQ Charcoal Produccion Line



BBQ Charcoal Produccion Line



Shuangliang Boiler

双良公司现有三个厂区占地28660平方米平方米，建筑面积14097平方米，职工人数168人，其中技术人员18名，高级工程师1名，工程师6名。主要生产设备156台件，固定资产 1729万元。最大起吊能力20t；最大卷板能力40×2500mm；钻孔能力 $\phi\leq 80\text{mm}$ ；弯管 $\phi\leq 219\text{mm}$ ；冲压封头 $\phi\leq 1800\text{mm}$ ；机床加工能力 $\phi 2600\times 500$ 和 $\phi 800\times 7500\text{mm}$ 。集机床加工、卷板、弯管、压制封头、冲剪、折弯、无损检测、理化试验等多功能于一身的综合性民营企业。

“环保节能、质优价廉”是双良人的服务宗旨。开发出“煤洁净燃烧蒸汽、热水、火焰、热风、热油炉”五大系列。产品均通过河北省环境保护局检测中心检测。锅炉的烟尘排放浓度、SO₂排放浓度、烟气林格曼黑度均达到《锅炉大气污染排放标准》

（GB13271—2001）Ⅱ时段二类区标准，并颁发了“环境保护产品使用认可证书”，证书编号：冀环产认字（2005）100号。锅炉、压力容器产品通过河北省锅炉压力容器监督检测所的监督检测，并逐台签发产品安全性能监督检验证书。其中我公司自主研发的“煤洁净燃烧蒸汽锅炉”，型号为LSG0.5-0.09/200-AⅢ热工检测效率为80.99%，

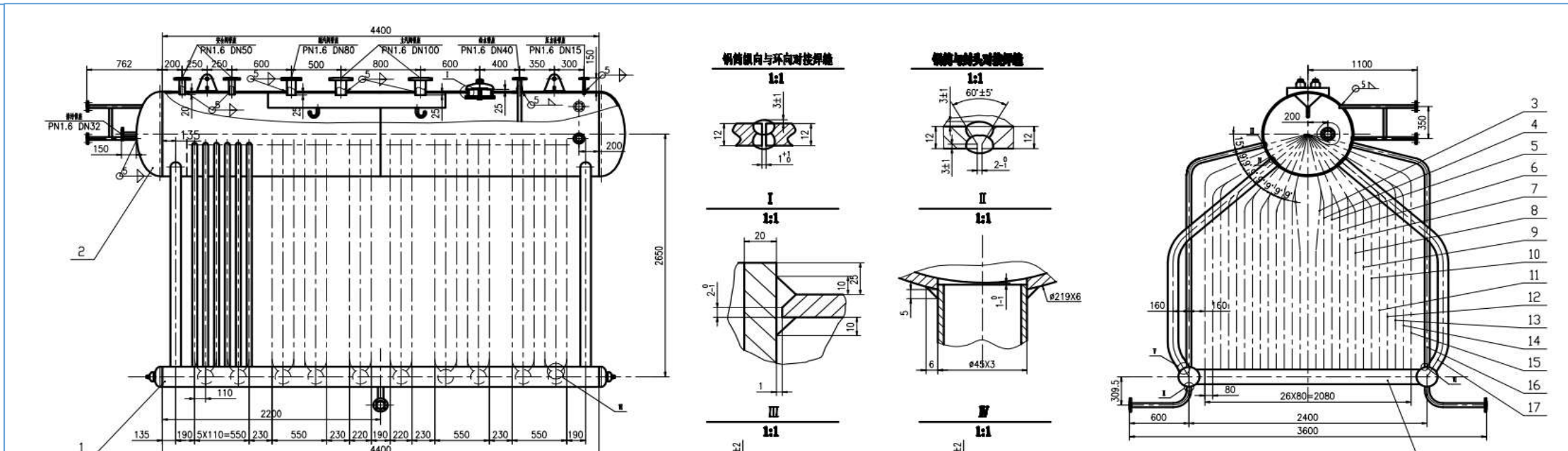

Shuangliang Boiler

副本

中华人民共和国
特种设备制造许可证
Manufacture License of Special Equipment
People's Republic of China

(锅炉)

编号: TS2110192-2017

单位名称: 河北双良锅炉容器有限公司
制造地址: 河北省石家庄市辛集市建材路9号

经审查, 获准从事下列锅炉的制造:

B级锅炉

审批机关: 国家质量监督检验检疫总局
有效期至: 2017年7月18日

发证机关: 国家质量监督检验检疫总局
发证日期: 2013年7月19日



副本

中华人民共和国
特种设备安装改造维修许可证
Installation, Alteration, Repair & Maintenance License of Special Equipment
People's Republic of China

(锅炉)

编号: TS3113045-2017

单位名称: 河北双良锅炉容器有限公司
单位地址: 河北省石家庄市辛集市建材路9号

经审查, 获准从事下列锅炉的安装、维修:

施工类别	级别	范围/参数
安装、维修	3	额定出口压力 $P < 1.6\text{MPa}$ 的整(组)装锅炉; 现场安装、组装铸铁锅炉。

审批机关: 河北省质量技术监督局
有效期至: 2017年5月2日

发证机关: 河北省质量技术监督局
发证日期: 2013年5月31日



副本

中华人民共和国
特种设备制造许可证
Manufacture License of Special Equipment
People's Republic of China

(压力容器)

编号: TS2213031-2015

单位名称: 河北双良锅炉容器有限公司
制造地址: 河北省石家庄市辛集市建材路9号

经审查, 获准从事下列压力容器的制造:

级别	品种范围	备注
D1	第一类压力容器	
D2	第二类低、中压容器	

审批机关: 河北省质量技术监督局
有效期至: 2015年12月30日

发证机关: 河北省质量技术监督局
发证日期: 2013年12月31日





生产场地 Factory



生产场地 Factory



50 卷板机 50mm thickness rolling machine



自动焊机 auto welding machine



量度计 Nirmeter



超声波探伤仪 Ultrasonic flaw detector



40 卷板机 40mm thickness rolling machine



电焊机 welding machine



观片灯 microscope



测厚仪 Thickness gauge



力学性能试验室 Mechanical property test chamber



电焊机 2015/5/20



空气压缩机 air compressor



焊材库 welding materials stock



烘干设备 drying equipment



空气加湿机 Air humidifier



理化试验室 Physical and chemical laboratory



弯管机 Pipe bending machine



空气压缩机 air compressor



烘干设备 drying machine



焊条保温筒 Welding rod insulation tube



试压泵 pressure testing pump



Rotary Dryer and AC Kiln



Xingyuan Machinery

Insolation Machinery



企业简介

Enterprise Introduction

辛集市兴源机械设备有限公司始建于1998年，是生产全自动、半自动、手动预发泡机、全自动板材成型机、切割机的专业厂家，集设备研发、制造、销售、安装及服务为一体。公司拥有泡沫制品厂、EPS原料仓库、泡塑机械厂和多个实验工厂。公司位于中国北方皮都——辛集，紧邻307国道，交通便利，公司注册资金200万，占地面积24000平方米，年产值3800万元。公司技术力量雄厚，生产设备先进，并长年与河北电力勘测设计研究院、华北电力设计院等科研部门建立科技协作关系。公司于2004年通过ISO9001国际质量管理体系认证，高品质的产品和高效率的服务已得到社会各界越来越多的了解和认同。

公司不断完善，持续改进，陆续推出了全自动预发泡机、全自动板材成型机、切割机等一系列产品。品种规格齐全，广泛应用于电力、工业、商业、公共建筑等领域。多年来，公司积极吸收世界先进技术，不断追求品质进步和技术创新，以提升产品结构、工艺和制造水平，同时公司始终把产品售后服务作为企业长期永续经营的基础的生命线，在多年优质服务实践的基础上已形成了一套规范、科学的售后服务管理运作程序。在不断完善泡塑机械产品的同时，我公司研发的XPS聚苯乙烯挤塑板生产线，彩钢夹芯生产线、舒乐舍板生产线、钢结构生产线，均达到国内先进水平。

"质量是生命、顾客是上帝、创新是动力、服务是后盾"，辛集市兴源机械设备有限公司始终秉承这一方针，在互惠互利，共同发展的基础上与您共创美好未来。



EPS&XPS panel is a kind of wall insulate material .like EXPO 2010 SHANGHAI ,HOME OF HIDDEN ENERGIES. Xingyuan Machinery factory is based on the Wall Insulate EPS ,XPS panel expanding and extruding machinery , already have about 18years history.

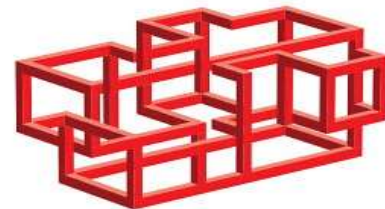

EXPO 2010 SHANGHAI 上海2010世博会
HAMBURG HOUSE
汉堡之家
HOME OF HIDDEN ENERGIES 灵气博爱的家园

Xingyuan Insulate machinery main products:

- EPS Expanding machine
- EPS plate foaming machine
- EPS shape molding machine
- Phenolic panel machine
- XPS plate extruding machine
- Foam cutting machine



- 该机主要零件均采用名牌产品, 经设备设计司: 周队长, 再会更光, 生产效率高。
- 在生产过程中控制更简单。
- 以新方式, 刀片制造薄片到任意厚度。

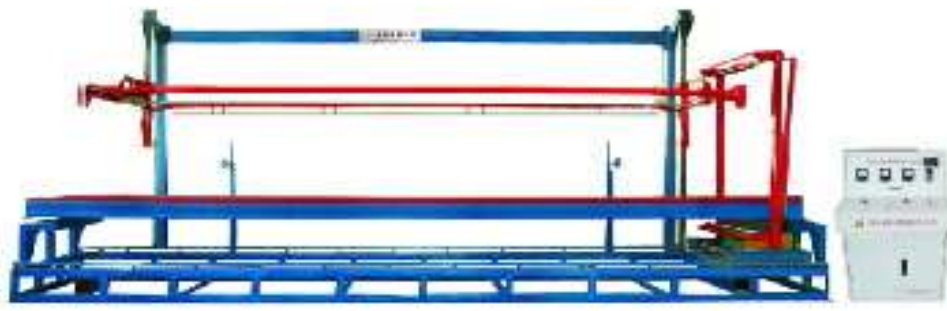
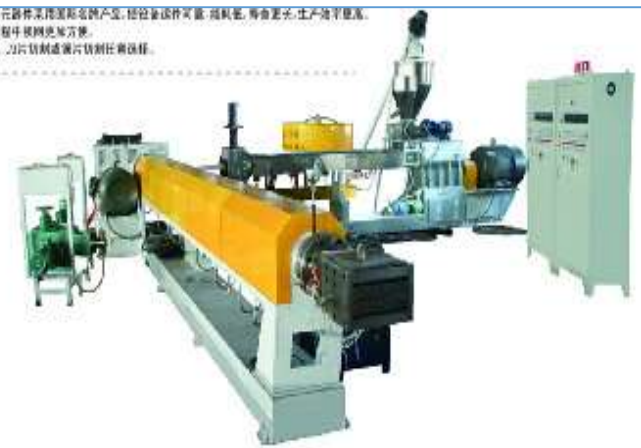

Xingyuan Machinery

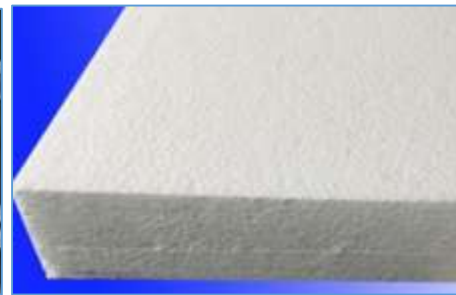

Xingyuan Machinery New Factory



Xingyuan Machinery New Factory





兴源实业

XINGYUAN GROUP

XINGYUAN INDUSTRY GROUP

兴源实业集团

XINGYUAN INDUSTRY GROUP \ 兴源实业集团

Add: Xingyuan Group Building, Nanlv Industry Zone, Xinji City, Hebei China

总公司办公地址：河北省辛集市南吕村工业区兴源实业大楼

Tel/Fax: +86-311-83333333

C.P. : +86-13473768866

Email: info@xygrup.cn

www.xygrup.cn

Xingyuan Group :

Xingyuan Agriculture
Xingyuan Activated Carbon
Xingyuan Foam Plastic
Xingyuan Machinery
Yuanxiang Chemical
Shuangliang Boiler Equipment
Xingyuan Biotech
PT.Xingyuan Indonesia Carbon Active
Anguo Shenjie Ecotech
Yantai Dinglong Reactivation
Dingang Impex